

7SG1641 Ohmega 402 50

Distance Protection Relay

Document Release History

This document is issue 2010/02. The list of revisions up to and including this issue is:
Pre release

| | |
|---------|----------------------------------|
| 2010/02 | Document reformat due to rebrand |
| | |
| | |

Software Revision History

| | | |
|---------|---------------|--|
| 2004/03 | 2615H80031R21 | |
|---------|---------------|--|

The copyright and other intellectual property rights in this document, and in any model or article produced from it (and including any registered or unregistered design rights) are the property of Siemens Protection Devices Limited. No part of this document shall be reproduced or modified or stored in another form, in any data retrieval system, without the permission of Siemens Protection Devices Limited, nor shall any model or article be reproduced from this document unless Siemens Protection Devices Limited consent.

While the information and guidance given in this document is believed to be correct, no liability shall be accepted for any loss or damage caused by any error or omission, whether such error or omission is the result of negligence or any other cause. Any and all such liability is disclaimed.

Contents

- 1 Menu Settings..... 3**
- 2 Settings Walkthrough 9**
 - 2.1 System Config Menu..... 10
 - 2.2 Distance Protection Menu 11
 - 2.3 Power Swing Menu 13
 - 2.4 Aux Protection Menu..... 14
 - 2.5 Reylogic Config 16
 - 2.6 Status Config 17
 - 2.7 Output Config..... 19
 - 2.8 Output Relay Dwell Time Menu 20
 - 2.9 Led Configuration Menu 20
 - 2.10 Data Staorage Menu 20
 - 2.11 Communications Menu 20
 - 2.12 Fault Locator Menu 21

1 Menu Settings

System Configuration Menu

| Setting | Range | Default |
|-------------------------|---|------------|
| Active Group | 1, 2 ... 8 | 1 |
| CVT in use | YES, NO | NO |
| CT Ratio | 0, 100, ... 5000: 1,2,5 | 2000:1 |
| VT Ratio | 1000, 1100, ... 10000, 11000, ... 600000: 90, 95, ... 130 | 132000:110 |
| Alternate Setting Group | 1, 2 ... 8 | 1 |
| View/Edit Group | 1, 2 ... 8 | 1 |
| Default Screens Timer | Off..60 | 60 |
| Date | | 1/ 1/1980 |
| Time | | 00:00:00 |
| Backlight timer | Off..60 | 5 |
| Change Password | AAAA ... ZZZZ | NOT ACTIVE |
| Relay Identifier | Up to 16 characters | OHMEGA |

Distance Protection Menu

| Setting | Range | Default |
|-----------------------|--|--------------|
| Active Scheme | Time Stepped, PUR, POR1, POR2, BOR | Time Stepped |
| CT Secondary | 1, 2, 5 | 1A |
| Line Angle | 0, 5, ... 90 Deg | 75 Deg |
| EF Comp Z0/Z1 ratio | 0, 0.01, ... 10.00 | 2.50 |
| EF Comp Z0 angle | 0, 5, ... 355 Deg | 75 Deg |
| Z1 Phase Fault | Enabled, Disabled | Enabled |
| Z1 PF Impedance | 0.5, 0.51, ... 10.0, 10.1, 10.2, ... 100, 101, ... 250 Ω | 8.00 Ohm |
| Z1 PF Time Delay | 0, 10, ... 10000ms | 0ms |
| Z1 Earth Fault | Enabled, Disabled | Enabled |
| Z1 EF Impedance | 0.5, 0.51, ... 10.0, 10.1, 10.2, ... 100, 101, ... 250 Ω | 8.00 Ohm |
| Z1 EF Time Delay | 0, 10, ... 10000ms | 0ms |
| Z2 Phase Fault | Enabled, Disabled | Enabled |
| Z2 PF Impedance | 0.5, 0.51, ... 10.0, 10.1, 10.2, ... 100, 101, ... 250 Ω | 16.00 Ohm |
| Z2 PF Time Delay | 0, 10, ... 10000ms | 1000ms |
| Z2 Earth Fault | Enabled, Disabled | Enabled |
| Z2 EF Impedance | 0.5, 0.51, ... 10.0, 10.1, 10.2, ... 100, 101, ... 250 Ω | 16.00 Ohm |
| Z2 EF Time Delay | 0, 10, ... 10000ms | 1000ms |
| Z3 Phase Fault | Enabled, Disabled | Enabled |
| Z3 PF Type | Fwd Mho, Rev Mho, Offset Mho, Offset Shaped | Offset Mho |
| Z3 PF Impedance (Fwd) | 0.5, 0.51, ... 10.0, 10.1, 10.2, ... 100, 101, ... 250 Ω | 24.00 Ohm |
| Z3 PF Impedance (Rev) | 0.5, 0.51, ... 10.0, 10.1, 10.2, ... 100, 101, ... 250 Ω | 8.00 Ohm |
| Z3 PF Shape Factor 1 | 0, 0.01, ... 1.00 | 1.00 |

| | | |
|-----------------------|--|------------|
| Z3 PF Shape Factor 2 | 0, 0.01, ... 1.00 | 1.00 |
| Z3 PF Time Delay | 0, 10, ... 10000ms | 2000ms |
| Z3 Earth Fault | Enabled, Disabled | Enabled |
| Z3 EF Type | Fwd Mho, Rev Mho, Offset Mho | Offset Mho |
| Z3 EF Impedance (Fwd) | 0.5, 0.51, ... 10.0, 10.1, 10.2, ... 100, 101, ... 250 Ω | 24.00 Ohm |
| Z3 EF Impedance (Rev) | 0.5, 0.51, ... 10.0, 10.1, 10.2, ... 100, 101, ... 250 Ω | 8.00 Ohm |
| Z3 EF Time Delay | 0, 10, ... 10000ms | 2000ms |
| Direct Zone 4 Trip | ENABLE, DISABLE | DISABLE |
| Z4 Phase Fault | Enabled, Disabled | Enabled |
| Z4 PF Impedance | 0.5, 0.51, ... 10.0, 10.1, 10.2, ... 100, 101, ... 250 Ω | 8.00 Ohm |
| Z4 PF Time Delay | 0, 10, ... 10000ms | 0ms |
| Z4 Earth Fault | Enabled, Disabled | Enabled |
| Z4 EF Impedance | 0.5, 0.51, ... 10.0, 10.1, 10.2, ... 100, 101, ... 250 Ω | 8.00 Ohm |
| Z4 EF Time Delay | 0, 10, ... 10000ms | 0ms |
| | | |
| | | |
| | | |

Power Swing Menu

| Setting | Range | Default |
|-------------------------|-----------------------------------|----------|
| Power Swing Detector | ENABLE, DISABLE | ENABLE |
| PSD Zone blocking | Zone 1 Zone 2 Zone 3 Zone 4 | Zone2-4 |
| PSD Shape | CIRCULAR, RECTANGULAR | CIRCULAR |
| PSD Blinders | ENABLE, DISABLE | DISABLE |
| PSD Inner Fwd Impedance | 0.1, 0.2, ... 250.0Ω | 24.0 Ohm |
| PSD Inner Rev Impedance | 0.1, 0.2, ... 250.0Ω | 8.0 Ohm |
| PSD Inner Fwd Blinder | 0.1, 0.2, ... 250.0Ω | 16.0 Ohm |
| PSD Inner Rev Blinder | 0.1, 0.2, ... 250.0Ω | 16.0 Ohm |
| PSD Outer Multiplier | 1.05, 1.06, ... 2.00 | 1.50x |
| PSD Transit Time | 0, 5, ... 1000ms | 50ms |

Auxiliary Protection Menu

| Setting | Range | Default |
|-------------------------|-------------------------------|-----------------|
| High Set | (Disabled..Enabled) | Enabled |
| HS Level | (0.1..35) | 4 x In |
| HS Time Delay | (0..1000) | 0ms |
| Stub Protection | (DISABLE..ENABLE) | ENABLED |
| SP Level | (0.1..2) | 1 xIn |
| SP Delay | (0..1000) | 0ms |
| SOTF | (Disabled..Enabled) | Enabled |
| SOTF Mode | (AC SOTF..DC SOTF) | AC SOTF |
| SOTF O/C Operate Level | (0.3..4) | 0.3 x In |
| VT Supervision | (Disabled..Enabled) | Enabled |
| VTS Latched Operation | (Disabled..Enabled) | Enabled |
| VTS Mode | (Alarm Only..Alarm & Inhibit) | Alarm & Inhibit |
| VTS Phase Fault Inhibit | (Disabled..Enabled) | Enabled |
| VTS Input Source | (Res I/V...NPS I/V) | Res I/V |
| VTS Ires Level | (0.05..2) | 0.3 x In |
| VTS Vop Level | (1..100) | 20v |

| | | |
|-----------------|---------|-----|
| VTS 3PV Level | (1..70) | 20v |
| VTS 3PLOV Delay | (0..10) | 1s |

Reylogic Config Menu

| Setting | Range | Default |
|---------------------------|---|---------|
| SR Dropoff | 0, 1, ... 1000, 1010, ... 10000, 10100, ... 60000ms | 1ms |
| SS Dropoff | 0, 1, ... 1000, 1010, ... 10000, 10100, ... 60000ms | 1ms |
| Permissive Trip Time | 0, 1, ... 1000, 1010, ... 10000, 10100, ... 60000ms | 20ms |
| Min AUX DC SOTF Dead Time | 0, 1, ... 1000, 1010, ... 10000, 10100, ... 60000ms | 10000ms |
| AC SOTF Pickup Delay | 0, 1, ... 1000, 1010, ... 10000, 10100, ... 60000ms | 10000ms |
| DC SOTF Active Timer | 0, 1, ... 1000, 1010, ... 10000, 10100, ... 60000ms | 400ms |
| VTS Alarm Delay | 0, 1, ... 1000, 1010, ... 10000, 10100, ... 60000ms | 100ms |
| VTS Latch PU Delay | 0, 1, ... 1000, 1010, ... 10000, 10100, ... 60000ms | 5000ms |

Status Config Menu

| Setting | Range | Default |
|----------------------|----------------|---------|
| Reset LED Flags | NONE, 1 ... 27 | NONE |
| Enable Stub Prot'n | NONE, 1 ... 27 | 5 |
| Unstabilise Relay | NONE, 1 ... 27 | NONE |
| Z2 TD Override | NONE, 1 ... 27 | 2 |
| DAR Lockout Latch | NONE, 1 ... 27 | 1 |
| Signal Receive 1 | NONE, 1 ... 27 | 7 |
| Carrier Recv. Guard | NONE, 1 ... 27 | NONE |
| DC SOTF Manual Close | NONE, 1 ... 27 | NONE |
| VT Ccts Isolated | NONE, 1 ... 27 | 8 |
| 3 Ph V Chk Enable | NONE, 1 ... 27 | 9 |
| Block Mode Inhibit | NONE, 1 ... 27 | 6 |
| Trigger Storage | NONE, 1 ... 27 | NONE |
| Inhibit Outputs | NONE, 1 ... 27 | NONE |
| Input 1 | NONE, 1 ... 27 | NONE |
| Input 2 | NONE, 1 ... 27 | NONE |
| Input 3 | NONE, 1 ... 27 | NONE |
| Input 4 | NONE, 1 ... 27 | NONE |
| Input 5 | NONE, 1 ... 27 | NONE |
| Input 6 | NONE, 1 ... 27 | NONE |
| Input 7 | NONE, 1 ... 27 | NONE |
| CB Closed | NONE, 1 ... 27 | NONE |
| Start AUX DC SOTF | NONE, 1 ... 27 | NONE |
| Switch Settings Grp | NONE, 1 ... 27 | NONE |
| Inhibit Group Switch | NONE, 1 ... 27 | NONE |
| Inverted Inputs | NONE, 1 ... 27 | NONE |

Output Config Menu

| Setting | Range | Default |
|--------------------|----------------|---------|
| Protection Healthy | NONE, 1 ... 29 | 1 |
| Zone 1 | NONE, 1 ... 29 | 18 |
| Zone 2 | NONE, 1 ... 29 | 19 |
| Zone 3 | NONE, 1 ... 29 | 25 |
| Zone 4 | NONE, 1 ... 29 | 25 |
| Zone 1 Start | NONE, 1 ... 29 | NONE |
| Zone 2 Start | NONE, 1 ... 29 | 26 |
| Zone 3 Start | NONE, 1 ... 29 | 27 |
| Zone 4 Start | NONE, 1 ... 29 | 27 |
| Phase A Fault | NONE, 1 ... 29 | 10 |
| Phase B Fault | NONE, 1 ... 29 | 11 |
| Phase C Fault | NONE, 1 ... 29 | 9 |
| Earth Fault | NONE, 1 ... 29 | NONE |
| Trip Output | NONE, 1 ... 29 | 7-8 |

| | | |
|---------------------|----------------|----------|
| Aided Trip | NONE, 1 ... 29 | 14 |
| High Set | NONE, 1 ... 29 | 29 |
| Stub Protection | NONE, 1 ... 29 | 13,17,24 |
| Z2 TD Override Trip | NONE, 1 ... 29 | 15 |
| Zone 4 Trip | NONE, 1 ... 29 | NONE |
| SOTF Operated | NONE, 1 ... 29 | 16 |
| DAR Lockout | NONE, 1 ... 29 | 3-6 |
| Power Swing Alarm | NONE, 1 ... 29 | NONE |
| VTS Alarm | NONE, 1 ... 29 | 12 |
| 3 Ph V Chk Alarm | NONE, 1 ... 29 | 12 |
| Signal Send 1 | NONE, 1 ... 29 | 21-23 |
| Signal Received 1 | NONE, 1 ... 29 | 20 |
| Carrier Failed | NONE, 1 ... 29 | NONE |
| Input 1 Operated | NONE, 1 ... 29 | NONE |
| Input 2 Operated | NONE, 1 ... 29 | NONE |
| Input 3 Operated | NONE, 1 ... 29 | NONE |
| Input 4 Operated | NONE, 1 ... 29 | NONE |
| Input 5 Operated | NONE, 1 ... 29 | NONE |
| Input 6 Operated | NONE, 1 ... 29 | NONE |
| Input 7 Operated | NONE, 1 ... 29 | NONE |
| Hand Reset Outputs | NONE, 1 ... 29 | NONE |
| Fast Reset Outputs | NONE, 1 ... 29 | NONE |
| Inhibitt Outputs | NONE, 1 ... 29 | NONE |

Output Relay Dwell Time Menu

| Setting | Range | Default |
|----------------|-----------------|---------|
| Min Op Time 1 | 1,10 ... 2000ms | 100ms |
| Min Op Time 2 | 1,10 ... 2000ms | 100ms |
| Min Op Time 3 | 1,10 ... 2000ms | 100ms |
| Min Op Time 4 | 1,10 ... 2000ms | 100ms |
| Min Op Time 5 | 1,10 ... 2000ms | 100ms |
| Min Op Time 6 | 1,10 ... 2000ms | 100ms |
| Min Op Time 7 | 1,10 ... 2000ms | 100ms |
| Min Op Time 8 | 1,10 ... 2000ms | 100ms |
| Min Op Time 9 | 1,10 ... 2000ms | 100ms |
| Min Op Time 10 | 1,10 ... 2000ms | 100ms |
| Min Op Time 12 | 1,10 ... 2000ms | 100ms |
| Min Op Time 13 | 1,10 ... 2000ms | 100ms |
| Min Op Time 14 | 1,10 ... 2000ms | 100ms |
| Min Op Time 15 | 1,10 ... 2000ms | 100ms |
| Min Op Time 16 | 1,10 ... 2000ms | 100ms |
| Min Op Time 17 | 1,10 ... 2000ms | 100ms |
| Min Op Time 18 | 1,10 ... 2000ms | 100ms |
| Min Op Time 19 | 1,10 ... 2000ms | 100ms |
| Min Op Time 20 | 1,10 ... 2000ms | 100ms |
| Min Op Time 21 | 1,10 ... 2000ms | 100ms |
| Min Op Time 22 | 1,10 ... 2000ms | 100ms |
| Min Op Time23 | 1,10 ... 2000ms | 100ms |
| Min Op Time 24 | 1,10 ... 2000ms | 100ms |
| Min Op Time 25 | 1,10 ... 2000ms | 100ms |
| Min Op Time 26 | 1,10 ... 2000ms | 100ms |
| Min Op Time 27 | 1,10 ... 2000ms | 100ms |
| Min Op Time 28 | 1,10 ... 2000ms | 100ms |
| Min Op Time 29 | 1,10 ... 2000ms | 100ms |

Led Config Menu

| Setting | Range | Default |
|---------------------|----------------|---------------|
| Zone 1 | NONE, 1 ... 29 | 1 |
| Zone 2 | NONE, 1 ... 29 | 2 |
| Zone 3 | NONE, 1 ... 29 | 3 |
| Zone 4 | NONE, 1 ... 29 | 4 |
| Zone 1 Start | NONE, 1 ... 29 | NONE |
| Zone 2 Start | NONE, 1 ... 29 | NONE |
| Zone 3 Start | NONE, 1 ... 29 | NONE |
| Zone 4 Start | NONE, 1 ... 29 | NONE |
| Phase A Fault | NONE, 1 ... 29 | 6 |
| Phase B Fault | NONE, 1 ... 29 | 7 |
| Phase C Fault | NONE, 1 ... 29 | 8 |
| Earth Fault | NONE, 1 ... 29 | 9 |
| Trip Output | NONE, 1 ... 29 | NONE |
| Aided Trip | NONE, 1 ... 29 | 11 |
| High Set | NONE, 1 ... 29 | 19 |
| Stub Protection | NONE, 1 ... 29 | 20 |
| Z2 TD Override Trip | NONE, 1 ... 29 | 25 |
| Zone 4 Trip | NONE, 1 ... 29 | NONE |
| SOTF Operated | NONE, 1 ... 29 | 17 |
| DAR Lockout | NONE, 1 ... 29 | NONE |
| Power Swing Alarm | NONE, 1 ... 29 | 24 |
| VTS Alarm | NONE, 1 ... 29 | 18 |
| 3 Ph V Chk Alarm | NONE, 1 ... 29 | 18 |
| Signal Send 1 | NONE, 1 ... 29 | NONE |
| Signal Received 1 | NONE, 1 ... 29 | 10 |
| Carrier Failed | NONE, 1 ... 29 | NONE |
| Input 1 Operated | NONE, 1 ... 29 | NONE |
| Input 2 Operated | NONE, 1 ... 29 | NONE |
| Input 3 Operated | NONE, 1 ... 29 | NONE |
| Input 4 Operated | NONE, 1 ... 29 | NONE |
| Input 5 Operated | NONE, 1 ... 29 | NONE |
| Input 6 Operated | NONE, 1 ... 29 | NONE |
| Input 7 Operated | NONE, 1 ... 29 | NONE |
| Self Reset LEDs | NONE, 1 ... 29 | 4, 10, 18, 24 |

Data Storage Menu

| Setting | Range | Default |
|---------------------|------------------------|------------|
| Pre-trigger Storage | 10 ... 90% | 20% |
| Record Duration | 10x1s,5x2s,2x5s &1x10s | 10 x 1 sec |

Communications Menu

| Setting | Range | Default |
|-----------------|--|------------|
| Station Address | 0, 1, ... 254 | 0 |
| IEC870 on port | COM1, COM2 | COM1 |
| COM1 Baud Rate | 75, 110, 300, 600, 1200, 2400, 4800, 9600, 19200, 38400, 57600, 115200 | 19200 |
| COM1 Parity | Even, Odd, None | EVEN |
| COM1 Line Idle | Light On, Light Off | LIGHT OFF |
| COM1 Data Echo | Off, On | OFF |
| COM2 Baud Rate | 75, 110, 300, 600, 1200, 2400, 4800, 9600, 19200, 38400, 57600, 115200 | 19200 |
| COM2 Parity | Even, Odd, None | NONE |
| COM2 Line Idle | Light On, Light Off | LIGHT OFF |
| COM2 Data Echo | Off, On | OFF |
| COM2 Direction | Auto-Detect, Rear Port, Front Port | FRONT PORT |

Fault Locator Menu

| Setting | Range | Default |
|----------------------------|--|----------------|
| Fault Locator | Enabled, Disabled | Enabled |
| Pos Seq Line Impedance | 0.1, 0.11, ..., 10, 10.1, ..., 100, 101, ..., 250 Ω | 10.00 Ohm |
| Sec'y Z+ per unit distance | 0.001, 0.002, ..., 5 Ω | 0.500 Ohm |
| Display distance as | Percent, Kilometres, Miles | Percent |

2 Settings Walkthrough

The relay displays are organised into three lists:-

A list of settings

A list of meters (instruments)

A list of fault records

This walkthrough describes the settings and is intended to be read in front of a powered-up relay. The starting point is the relay identifier screen. This is the screen the relay displays when it is first powered-up and can be reached from any display by pressing **CANCEL** a few times.

From this position press the down arrow key once, the relay will display "**SETTINGS MODE**".

From this display the down arrow key can be pressed again to enter the setting list, or the right arrow key ⇒ can be pressed to choose a different list ("**INSTRUMENTS MODE**" or "**FAULT DATA MODE**").

Press the down arrow key ↓. The relay enters the settings list and displays "**SYSTEM CONFIG MENU**".

2.1 System Config Menu

This menu contains general settings which allows the relay to be configured. Press ⇨ to open the menu and display the settings.

Active Group (1 ... 8) 1

This is the settings group which is currently being used by the relay. This is not necessarily the same group as those currently displayed.

CVT in use (NO..YES) NO

If CVT's are used then this setting should be set to YES. This will give extra security to the protection during the case of severe CVT transients. Due to this extra security, operation of the relay will be approximately 5ms slower if CVTs are being used.

CT Ratio (0:1..5000:5) 2000:1

This setting defines the turns ratio of the protection CT. This will allow the meter display to show the correct primary current. This setting does not affect any protection functions.

VT Ratio (1000:90..600000:130) 132000:110

This setting defines the ratio of the protection VT. This will allow the meter display to show the correct primary voltage. This setting does not affect any protection functions.

Alternate Setting Group (1..8) 1

It is possible to cause the relay to switch from one setting group to another on application of a signal to the Status Input *Use Alt Setting Grp*. When this status input is energised, the relay will switch from whichever group is currently active to the alternate group defined in this setting. The relay will revert to the previous active setting group when the *Use Alt Setting Grp* Status Input is de-energised.

View/Edit Group (1 ... 8) 1

This is the settings group which is currently being displayed by the relay. This is the group which would be changed if any setting is edited. This is not necessarily the same group as those currently in use.

Default Screens Timer (Off, 1-60 mins) 60

This is the time delay after which the relay will return to the default screen, if no keys are pressed.

Backlight timer (OFF..60) 5 min

Defines the length of time for which the backlight for the LCD screen will remain illuminated after the last keypress.

Change Password (Password) NONE

The relay is provided with a password feature. If set it will prevent any un-authorized changes to any of the relay settings. The password is a four character word once set it can be disabled by entering the new password "NONE". Once a password has been set, the relay will display a 10 digit code in the Change Password setting. If the password has been lost then an authorised person should contact a Siemens representative, quoting this 10-digit code. This can be used to obtain the current password.

The password must be entered in order to alter any of the relay settings. Once the password has been entered, the relay will remain "logged-in" for 1 hour. After this time, the relay password must be entered again before settings can be changed.

Relay Identifier (16 Character String) OHMEGA

The relay is supplied with a default identifier usually the relay type. This can be changed to any 16-digit identifier to give any meaningful identification to the relay. e.g. feeder name or circuit number.

2.2 Distance Protection Menu

The settings for the impedance elements are located in this menu.

Distance Scheme (Time Stepped, PUR, POR1, POR2 BOR) Time Stepped

There are a number of different protection schemes available in the relay depending upon the model. These can be chosen at this setting. Only one scheme can be active at a time. The schemes are described in Section 3 of this manual.

CT Secondary (1..5) 1 A

The relay can operate from 1, 2 or 5 Amp CT secondary circuits. The value MUST be programmed for the correct CT. This will affect the impedance measurements if not programmed correctly.

Line Angle (0..90) 75 deg

This is the angle of the positive sequence impedance of the composite transmission line.

EF Comp Z0/Z1 ratio (0..10) 2.5

This is the ratio between the magnitudes of the zero sequence and positive sequence impedances of the system. The ratio of Z0/Z1 is used in an internal calculation for earth-fault compensation. This is common for all Zones.

EF Comp Z0 angle (0..355) 75 deg

This is the angle of the zero sequence impedance of the system.

Z1 Phase Fault (Disabled..Enabled) Enabled

Operation of the Zone 1 phase-fault elements A-B, B-C & C-A, can be enabled or disabled from this setting.

Z1 PF Impedance (0.1..250) 8 ohms

Defines the Zone 1 phase-fault impedance reach in terms of the secondary positive sequence impedance.

Z1 PF Time Delay (0..10000) 0 ms

An independent time delay from 0 – 10s can be applied to the Zone 1 phase-fault protection elements.

Z1 Earth Fault (Disabled..Enabled) Enabled

Operation of the Zone 1 earth-fault elements A-E, B-E & C-E, can be enabled or disabled from this setting.

Z1 EF Impedance (0.1..250) 8 ohms

Defines the Zone 1 earth-fault impedance reach (in terms of secondary positive sequence impedance) for the mho characteristic.

Z1 EF Time Delay (0..10000) 0 ms

An independent time delay from 0 – 10s can be applied to the Zone 1 earth-fault protection elements.

Z2 Phase Fault (Disabled..Enabled) Enabled

Operation of the Zone 2 phase-fault elements A-B, B-C & C-A, can be enabled or disabled from this setting.

Z2 PF Impedance (0.1..250) 16 ohms

Defines the Zone 2 phase-fault impedance reach in terms of the secondary positive sequence impedance.

Z2 PF Time Delay (0..10000) 1000 ms

An independent time delay from 0 – 10s can be applied to the Zone 2 phase-fault protection elements.

Z2 Earth Fault (Disabled..Enabled) Enabled

Operation of the Zone 2 earth-fault elements A-E, B-E & C-E, can be enabled or disabled from this setting.

Z2 EF Impedance (0.1..250) 16 ohms

Defines the Zone 2 earth-fault impedance reach (in terms of secondary positive sequence impedance) for the mho characteristic.

Z2 EF Time Delay (0..10000) 1000 ms

An independent time delay from 0 – 10s can be applied to the Zone 2 earth-fault protection elements.

Z3 Phase Fault (Disabled..Enabled) Enabled

Operation of the Zone 3 phase-fault elements A-B, B-C & C-A, can be enabled or disabled from this setting.

Z3 PF Type (Fwd Mho, Rev Mho, Offset Mho, Offset Shaped) Offset Mho

There are three types of Zone 3 characteristic for phase-faults: Forward (Fwd) Mho, Reverse (Rev) Mho or Offset Mho. If either forward or reverse is selected then these elements become a standard directional element and

require a polarising voltage. If an offset characteristic is selected, then operation can occur without polarising voltage.

Z3 PF Impedance (Fwd) (0.1..250) 24 ohms

The Zone 3 phase-fault forward impedance reach is defined by this setting, in terms of secondary positive sequence impedance. If the element is selected as a reverse element then this setting is ignored.

Z3 PF Impedance (Rev) (0.1..250) 8 ohms

The Zone 3 phase-fault reverse impedance reach is defined by this setting, in terms of secondary positive sequence impedance. If the element is selected as a forward element then this setting is ignored.

Z3 PF Shape Factor 1 (0..1) 1

Z3 PF Shape Factor 2 (0..1) 1

Sets the relay shape factors where Zone 3 Shaped characteristics are being applied. If Shaped Zone 3 characteristics are not used, this setting will have no effect.

Z3 PF Time Delay (0..10000) 2000 ms

An independent time delay from 0 – 10s can be applied to the Zone 3 phase-fault protection elements.

Z3 Earth Fault (Disabled..Enabled) Enabled

Operation of the Zone 3 earth-fault elements A-E, B-E & C-E can be enabled or disabled from this setting.

Z3 EF Type (Fwd Mho..Offset Quad) Offset Mho

There are three types of Zone 3 characteristic for earth-faults: Forward (Fwd) Mho, Reverse (Rev) Mho or Offset Mho. If either forward or reverse is selected then these elements become a standard directional element and require a polarising voltage. If an offset characteristic is selected, then operation can occur without polarising voltage.

Z3 EF Impedance (Fwd) (0.1..250) 24 ohms

The Zone 3 earth-fault forward reach impedance values are defined using this setting, in terms of secondary positive sequence impedance. If the element is set as a reverse-looking element, this setting is ignored.

Z3 EF Impedance (Rev) (0.1..250) 8 ohms

The Zone 3 earth-fault reverse reach impedance values are defined using this setting, in terms of secondary positive sequence impedance. If the element is set as a forward-looking element, this setting is ignored.

Z3 EF Time Delay (0..10000) 2000 ms

An independent time delay from 0 – 10s can be applied to the Zone 3 earth-fault protection elements.

Direct Zone 4 Trip (DISABLE..ENABLE) DISABLE

This enables Zone 4 to issue a general trip when the Zone 4 operates. The Zone 4 is normally used for the blocking schemes only (i.e. it is a non-tripping zone), but it can be used to trip under certain circumstances.

Z4 Phase Fault (Disabled..Enabled) Enabled

The reverse Zone 4 phase-fault elements A-B, B-C & C-A, can be enabled or disabled from this setting.

Z4 PF Impedance (0.1..250) 8 ohms

Defines the Zone 4 phase-fault impedance reach (in terms of secondary positive sequence impedance) for the mho characteristic.

Z4 PF Time Delay (0..10000) 0 ms

An independent time delay from 0 – 10s can be applied to the Zone 4 phase-fault protection elements.

Z4 Earth Fault (Disabled..Enabled) Enabled

Operation of the Zone 4 earth-fault elements A-E, B-E & C-E, can be disabled from this setting.

Z4 EF Impedance (0.1..250) 8 ohms

Defines the Zone 4 earth-fault impedance reach (in terms of secondary positive sequence impedance) for the mho characteristic.

Z4 EF Time Delay (0..10000) 0 ms

An independent time delay from 0 – 10s can be applied to the Zone 4 earth-fault protection elements.

2.3 Power Swing Menu

Settings for the power swing element are defined in this section.

Power Swing Detector (DISABLE..ENABLE) ENABLE

This setting allows the Power Swing detector to be enabled or disabled.

PSD Zone blocking (4 Bit Binary) -111

This defines which Zones of protection tripping would be blocked for in the event of a Power Swing.

PSD Shape (CIRCULAR..RECTANGULAR) CIRCULAR

Allows setting of the Power Swing Zone characteristics as either circular or rectangular.

PSD Blinders (DISABLE..ENABLE) DISABLE

This allows blinders to be applied to the Power Swing Zone to prevent load encroachment. These are applied parallel to the line angle when enabled.

PSD Inner Fwd Impedance (0.1..250) 24 ohms

Sets the inner impedance reach in the forward direction (on the line angle) for the PSD characteristic. This is usually set equal to, or greater than, the Zone 3 reach.

PSD Inner Rev Impedance (0.1..250) 8 ohms

Sets the inner impedance reach in the reverse direction (on the line angle) for the PSD characteristic. This is usually set equal to, or greater than, the Zone 3 reverse reach.

PSD Inner Fwd Blinder (0.1..250) 16 ohms

This is the impedance (perpendicular to the line angle) between the line impedance and the blinder applied to the PSD Zone, to the right of the line characteristic. The blinder is applied parallel to the line angle.

PSD Inner Rev Blinder (0.1..250) 16 ohms

This is the impedance (perpendicular to the line angle) between the line impedance and the blinder applied to the PSD Zone, to the left of the characteristic. The blinder is applied parallel to the line angle.

PSD Outer Multiplier (1.05..2) 1.5 x

The outer reach of the Power Swing detector is set as a multiple of the inner reach, normally 1.5 times the inner reach.

PSD Transit Time (0..1000) 50 ms

This is the length of time for which the impedance characteristic must be between the inner and outer Zones of the Power Swing Detector for a Power Swing to be detected. The default setting of 50ms should be suitable for most applications.

2.4 Aux Protection Menu

Any additional protection elements are programmed in this section.

High Set (DISABLE..ENABLE) ENABLE

Overcurrent high set elements can be enabled or disabled using this setting.

HS Level (0.1..35) 4 xIn

The overcurrent setting is applied here. It is set in multiples of the nominal current, I_n which is set in the DISTANCE PROTECTION MENU under the *CT Secondary* setting.

HS Time Delay (0..1000) 0 ms

A definite time delay from 0 – 1s can be added to the instantaneous operating time of the high set elements.

Stub Protection (DISABLED..ENABLED) ENABLED

Allows the Stub Protection Element to be enabled or disabled.

SP Level

SP Delay

When the Stub Protection element is enabled, and the Status Input assigned to *Enable Stub Protection* is energised, the *Stub Protection output* will operate if the current is above the *SP Level* for longer than the *SP delay* time.

Switch On To Fault (DISABLED..ENABLED) ENABLED

This setting determines whether the Switch On To Fault protection is enabled or not.

SOTF Mode (AC SOTF..DC SOTF) AC SOTF

The Switch On To Fault feature has two modes of operation. It can be energised from an AC function or a DC function. The DC SOTF function is energised by the operation of a status input from the CB manual close handle (i.e. a D.C. signal). The AC SOTF function monitors the line current and voltage (i.e. the AC signals) and thus cannot be used if the VT is on the busbar side of the relay.

SOTF O/C Operate Level (0.3..4) 0.3 xIn

This current setting is used as a minimum value to cause operation of the SOTF function after 25ms of fault current on all three phases.

VT Supervision (DISABLED..ENABLED) ENABLED

This checks for the security of the VT circuit. It can be enabled or disabled.

VTS Latched Operation (DISABLED..ENABLED) ENABLED

If latched operation is enabled and a VTS operation remains on the system for more than the 'VTS Latch PU Delay', the VTS alarm and inhibit will not reset when current is detected above the setting. If this is disabled, the VTS will always reset when current is detected above the VTS setting.

VTS Mode (ALARM ONLY..ALARM & INHIBIT) ALARM & INHIBIT

If the VTS operates it can be selected to give an alarm only or it can inhibit the operation of the impedance elements.

VTS Phase Fault Inhibit (DISABLED..ENABLED) ENABLED

During a fault condition the VTS is reset when the zero sequence current exceeds the setting. For a phase-fault there is no zero sequence current therefore the relay may be inhibited during a phase-fault.

With this setting disabled, the relay will trip for a two-phase VT failure.

With this setting enabled, the relay will remain stable for a two-phase VT failure but will not trip if a phase-fault occurs during such a failure.

VTS Input Source (RES I/V...NPS I/V) Res I/V

VTS operation can be set based on Residual voltage and current or Negative phase sequence quantities.

VTS Ires Level (0.05..2) 0.3 xIn

VTS Vop Level (1..100) 20 V

The VTS feature operates by measuring the summated voltages of the healthy system, and comparing this with the measured residual current. The VTS will operate if the relay detects residual voltage without detecting a corresponding residual current. These settings define the levels of residual current and voltage used. The default residual voltage setting of 20 volts is suitable for most applications, but this can be changed to make the function more or less sensitive. The current setting is made in terms of the nominal current, and the default setting is 30%. The default settings used here are suitable for most applications.

VTS 3PV Level

VTS 3PLOV Delay

A status input defined as 3 Ph V Chk Enable, can be defined. This is energised whenever the voltage on the system should be live. If is status input is energised, and the relay checks that the voltage is live. If it detects voltage below the *VTS 3PV Level*, the *3 Ph V Chk Alarm* output will operate.

2.5 Reylogic Config

Elements of functions that have had the logic configured in REYLOGIC are found in this menu.

SR Dropoff (0..60000) 1 ms

The Distance signal received can be extended using this timer to provide a variable pulse length.

SS Dropoff (0..60000) 1 ms

The Distance send signal can be delayed using this timer to provide a variable pulse length.

Permissive Trip Time (0..60000) 1 ms

This is used for the distance blocked overreach scheme (BOR). This is the time for which the relay will wait for a blocking signal from the remote end before a carrier-aided trip is carried out.

Min AUX DC SOTF Dead Time (0..60000) 10000 ms

The logic requires that the circuit breakers must have been closed for a minimum time before the SOTF logic is initiated. This minimum time is set here. This setting is used for DC SOTF driven by CB auxiliary contacts only.

AC SOTF Pickup Delay (0..60000) 10000 ms

The logic requires that the circuit breakers must have been closed for a minimum time before the SOTF logic is initiated. This minimum time is set here.

DC SOTF Active Timer (0..60000) 400 ms

This setting fixes the time for which DC SOTF will be enabled after starting from a manual close handle or CB auxiliary contact.

VTS Alarm Delay (0..60000) 100 ms

Specifies the time for which a VTS condition must be present on the system before a VTS alarm is raised. This is set to avoid nuisance alarms.

VTS Latch PU Delay (0..60000) 5000 ms

This is the minimum time that the VT fail conditions must remain on the system before the VT alarm is operated. It is usually set to 5000ms to avoid nuisance alarms.

2.6 Status Config

The number of status inputs can vary with the relay model type. Each of the status inputs can be mapped to any one or more of the relay functions. The following list shows the purpose of the function.

Reset LED Flags (39 Character String) NONE
Energising this Status Input will reset all LED flags, in the same way as pressing the TEST/RESET button on the relay.

Enable Stub Protection

Where Stub Protection is applied, this status input should be connected to the primary plant auxiliary contacts, which indicate that the protected "stub" is not energised. When this status input is energised, and the Stub Protection is enabled, the Stub protection will operate if current above the *SP Level* is detected for longer than the *SP Delay*

Unstabilise Relay (39 Character String) NONE
When used this will cause the relay to issue a permissive signal or remove a blocking signal, depending on the selected scheme.

Z2 TD Override (30 Character String) NONE
When this Status Input is energised, the time delay will be removed from the Zone 2 element allowing it to trip instantaneously. This can be used when the remote end CB is open, and there is no chance of the Zone 2 operating for an out of zone fault.

DAR Lockout Latch (30 Character String) NONE
This status is fed back from the auto-reclose system to provide indication that the system is in lockout. The input is used to latch the backup trip flag output. This output will be reset when the status input resets assuming that the backup trip initiation has been removed.

Signal Receive 1 (39 Character String) NONE
Signalling channel used for Distance Protection.

Carrier Recv Guard (39 Character String) NONE
Where it is available, a signal may be taken from the signalling equipment, which will energise this status input when the signalling channel is faulty. This will cause the selected scheme to act as a time stepped distance scheme, until the SI is de-energised.

DC SOTF Manual Close (39 Character String) NONE
This status input must be used if the *Switch On To Fault mode* is set to *DC SOTF*. A contact is required from the circuit breaker closing handle. It is disabled by default. For 400ms after this element is first energised, the relay will remove the time delay from Zone 3. See Section 2 of this manual for a full description of the *Switch On To Fault* feature.

VT Circuits Isolated (39 Character String) NONE
Used where MCBs are used to isolate VTs. If all VT phases are lost, this SI should be energised to indicate a 3-phase VT failure.

3 Ph V Chk Enable (39 Character String) NONE
This input is used to enable the 3 pole loss of voltage alarm.

Block Mode Inhibit (39 Character String) NONE
Will inhibit operation of the *Blocked Overreach* scheme (where selected)

Trigger Storage (39 Character String) NONE
Energising this SI will trigger waveform storage.

Inhibit Outputs (39 Character String) NONE
Operation of all outputs which are designated in the output relay menu as inhibited, using the 'Inhibit Outputs' setting, will be blocked whilst this input is energised.

Input 1 ... 7

In order to utilise the status inputs and output relay matrix a number of connections have been created. These are named as Input 1..n where n is a maximum of 4. Energising the Status Input assigned here will cause the *Input X Operated* output to operate.

CB Closed (39 Character String) NONE
This input is driven from a circuit breaker auxiliary contact and used to inform the relay that the circuit breaker is closed.

Start AUX DC SOTF (39 Character String) NONE
Input connected to CB auxiliary contact to initiate DC SOTF from this source.

Switch Settings Grp (39 Character String) NONE
When this SI is energised, the relay will switch groups, from the currently active group to the *Alternate Setting Group* defined in the System Config Menu. The relay will remain in the alternate setting group until the SI is de-energised, when the relay will revert to the previous setting group.

Inhibit Group Switch (39 Character String) NONE
Energising this status input will prevent the relay from changing groups when the Switch Settings group Input is energised.

Inverted Inputs (39 Character String) NONE
Any inputs which are selected here will be inverted, i.e. de-energisation of the input will be considered as a logical '1' input to their applicable logic diagram.

2.7 Output Config

Depending upon the configuration of the relay there are a large number of signals which can be mapped to output contacts.

Protection Healthy (39 Character String) 1...

This output monitors the condition of the relay and dc power supply to the relay. This is usually mapped to one of the changeover outputs, and connected to the normally closed contact (by default relay 1). When this function is selected it will permanently operate the selected relay. By using a normally closed contact if there is any failure then this contact will close giving a fail-safe alarm condition.

Zone 1 (39 Character String) NONE

Zone 2 (39 Character String) NONE

Zone 3 (39 Character String) NONE

Zone 4 (39 Character String) NONE

Indicates the Zones involved in the fault. Note these outputs are not starters – they will have the same time-delayed operation as the zones themselves.

Zone 1 Start (39 Character String) NONE

Zone 2 Start (39 Character String) NONE

Zone 3 Start (39 Character String) NONE

Zone 4 Start (39 Character String) NONE

Indicates the Zones involved in the fault. This will indicate the non-time delayed operation of the zones, ie. the zone starters.

Phase A Fault (39 Character String) NONE

Phase B Fault (39 Character String) NONE

Phase C Fault (39 Character String) NONE

Indicates the phase(s) involved in the fault condition

Earth Fault (39 Character String) NONE

Operates when the fault involves an earth path.

Trip Output

This is used as the initiation for the tripping of the local circuit breaker. Depending on the settings of the relay, this may be operated by any of the distance elements, Highset Overcurrent, etc.

Aided Trip (39 Character String) NONE

Operates when the relay operation was aided by the active scheme, i.e. indicates whether it was a simple time stepped distance trip or not.

High Set (39 Character String) NONE

Indicates operation of the Highset Overcurrent element.

Stub Protection (39 Character String) NONE

Indicates Operation of the Stub Protection.

Z2 TD Override Trip

If the zone 2 TD Override feature is used, when the status input assigned to *Z2 TD Override* is energised, this output contact will operate.

Zone 4 Trip

When Direct Zone 4 tripping is enabled, and zone 4 operates, this output will be operated.

SOTF Operated (39 Character String) NONE

Indicates that a Switch-onto-fault Operation has occurred.

DAR Lockout (39 Character String) NONE

Operates when a trip occurs which should not initiate Autoreclose, i.e. a Zone 2 or Zone 3 fault. May be used to prevent operation of an external Autorecloser.

Power Swing Alarm (39 Character String) NONE

Operates when the System impedance characteristic has entered the Power Swing Detection Zone and remained there for longer than the *PSD Transit time*.

VTS Alarm (39 Character String) NONE

Operates when one or more phases of the Voltage Transformer fails.

3 Ph V Chk Alarm

Indicate that the three pole voltage check has operated. That is, the status input defined as *3 Ph V Chk Enable* is energised and the voltage is below the *VTS 3PV Level*.

Signal Send 1 (39 Character String) NONE
Operates according to the selected scheme to send either a permissive signal or a blocking signal to the remote end.

Signal Received 1 (39 Character String) NONE
Operates on receipt of a signal from the remote end distance relay.

Signal Received 2 (39 Character String) NONE
Not Used

Carrier Failed (39 Character String) NONE
Operates when the carrier guard SI has operated because of a faulty signalling channel.

Input 1..7 Operated (39 Character String) NONE
Each of these will operate when the respective inputs are energised.

Hand Reset Outputs (39 Character String) NONE
Indicates which Outputs are latched.

Fast Reset Outputs (39 Character String) NONE
Output relays selected here will be reset more frequently than standard relays.

Inhibit Outputs (39 Character String) NONE
Outputs relays listed here will be disabled when the Inhibit Inputs status input is energised.

2.8 Output Relay Dwell Time Menu

This menu is used to set a minimum operating time for each output relay in turn. i.e. if the stimulus causing the relay is of short duration the relay output operation will be extended beyond the drop-off of the stimulus.

2.9 Led Configuration Menu

With the exception of the "Protection Healthy" item, this menu has the same relay outputs as the output Configuration menu and these can be used to energise any of the LED flags.

2.10 Data Storage Menu

Pre-trigger Storage (10, 20, ... 90%)
Sets the percentage of the total record duration which is stored before the trigger picks up.

Record Duration (10x1sec, 5x2sec, 2x5sec, 1x10sec)
This setting selects the number and duration of waveform records, from 10 record, each of 1 second duration up to only 1 record of 10 seconds duration.

2.11 Communications Menu

Station Address (0, 1, ... 254) 0
Defines the relay address number. When set to zero, the relay will not communicate.

IEC870 on port (COM1, COM2)
Defines the port which uses IEC 870 Communication protocol. The front port and the top rear fibre Optic ports are denoted COM2. When using a PC to communicate locally with the relay, this should be set to COM2.
Note that this should not be confused with the comms port on the PC.

COM1 Baud Rate (75, 110, 300, 600, 1200, 2400, 4800, 9600, 19200, 38400, 57600, 115200)
Defines the Baud rate used by the COM 1 of the relay to communicate with an external device. The relay and the external device must both be using the same baud rate in order for communications to be established.

COM1 Parity (Even, Odd, *None*)

Defines the type of Parity used by the COM 1 of the relay when communicating with an external device. The relay and the external device must both be using the parity in order for communications to be established.

COM1 Line Idle (Light On, **Light Off**)

For the Fibre Optic port. Defines whether the fibre optic light will be ON or OFF when the line is idle.

COM1 Data Echo (**Off**, On)

This setting must be switched on, to enable the relay to pass data around a ring system. If a number of relays are connected together, the data echo feature must be switched on to allow data transfer. When communicating with a single relay it may be easier to switch this setting to OFF.

COM2 Baud Rate (75, 110, 300, 600, 1200, 2400, 4800, 9600, **19200**, 38400, 57600, 115200)

Defines the Baud rate used by the COM 1 of the relay to communicate with an external device. The relay and the external device must both be using the same baud rate in order for communications to be established.

COM2 Parity (Even, Odd, **None**)

Defines the type of Parity used by the COM 2 of the relay when communicating with an external device. The relay and the external device must both be using the parity in order for communications to be established.

COM2 Line Idle (Light On, **Light Off**)

For the Fibre Optic port. Defines whether the fibre optic light will be ON or OFF when the line is idle.

COM2 Data Echo (**Off**, On)

This setting must be switched on, to enable the relay to pass data around a ring system. If a number of relays are connected together, the data echo feature must be switched on to allow data transfer. When communicating with a single relay it may be easier to switch this setting to OFF.

COM2 Direction (Auto-Detect, Rear Port, Front Port)

The relay has two external connections to COM port 2 – via the rear fibre optic connection or via the front RS232 connection. This defines which port is used. When set as auto-detect it will switch between ports depending on the connected devices.

2.12 Fault Locator Menu

Pos Seq Line Impedance (0.1 – 250 Ω) 10 Ω

This is the positive sequence impedance of 100% of the line.

Sec'y Z+ per unit distance (0.1 – 250 Ω) 0.500 Ω

Defines the secondary positive sequence impedance per mile or kilometre.

Display distance as (*Percent, Kilometres, Miles*)

Defines whether the distance is displayed as a distance or as a percentage of the Pos Seq Line Impedance setting.

Fault Locator *Enabled/ Disabled*

Allows the fault locator to be enabled or disabled.

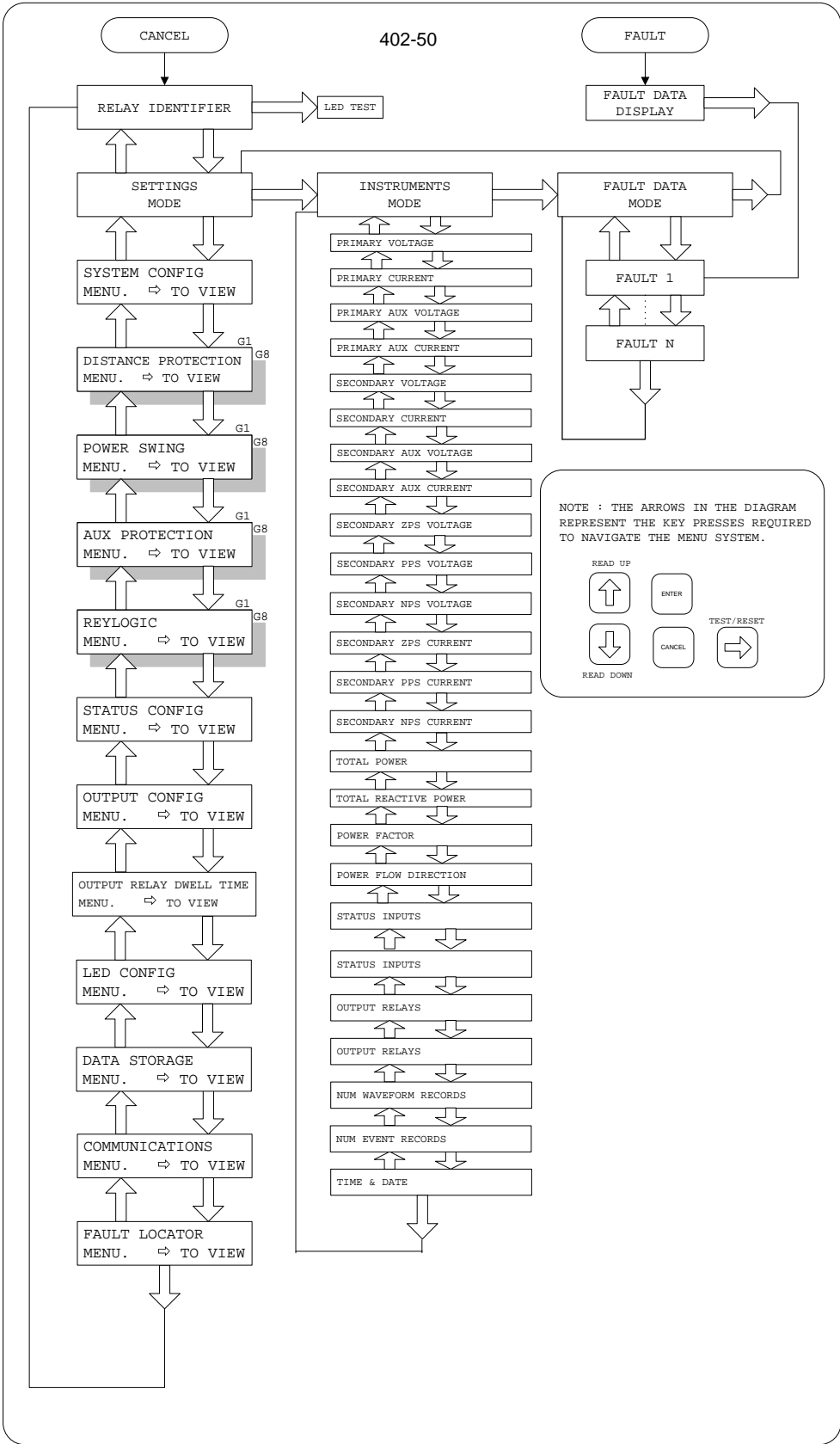

Menu Structure